

LP5900SD 6 Pin LLP Evaluation Board Information

National Semiconductor
Application Note 1494
John Bowie
August 2007



Introduction

This evaluation board is designed to enable the evaluation of the LP5900 Voltage Regulator. Each board is assembled and tested in the factory. This evaluation board has the 6 pin LLP package mounted.

General Description

The LP5900 is a linear regulator capable of supplying 150mA output current. Designed to meet the requirements of RF/Analog circuits, the LP5900 provides low device noise, high PSRR, low quiescent current, and low line transient response. Using new innovative design techniques the LP5900 offers class-leading noise performance without a noise bypass capacitor.

The device has been designed to work with 0.47 μ F input and output ceramic capacitors down to 0603 component size.

Operation

The input voltage, applied between V_{IN} and GND, should be at least 1.0V greater than V_{OUT} and no more than 5.5V. The minimum operating voltage is 2.5V. Loads can be connected to V_{OUT} with reference to GND. V_{OUT} and V_{IN} sense pins are provided on the board to allow accurate measurements directly onto the input and output pins of the device, eliminating any voltage drop on the PCB traces or connecting wires to the load.

ON/OFF control is provided by a logic signal on the V_{EN} pin. A minimum of 1.2V is required at this pin to enable the LDO. The LDO will be shutdown when the V_{EN} pin is set to 0.4V or less.

In applications where the LP5900 is operated continuously from the battery then V_{IN} and V_{EN} can be tied together. However if ON/OFF control is required the V_{EN} pin should be driven from a separate signal to ensure correct operation of the fast start-up circuit. The device has a 1M Ω internal resistor from V_{EN} to GND.

Hardware

The schematic and layout of the evaluation board are given below:

Schematic Diagram

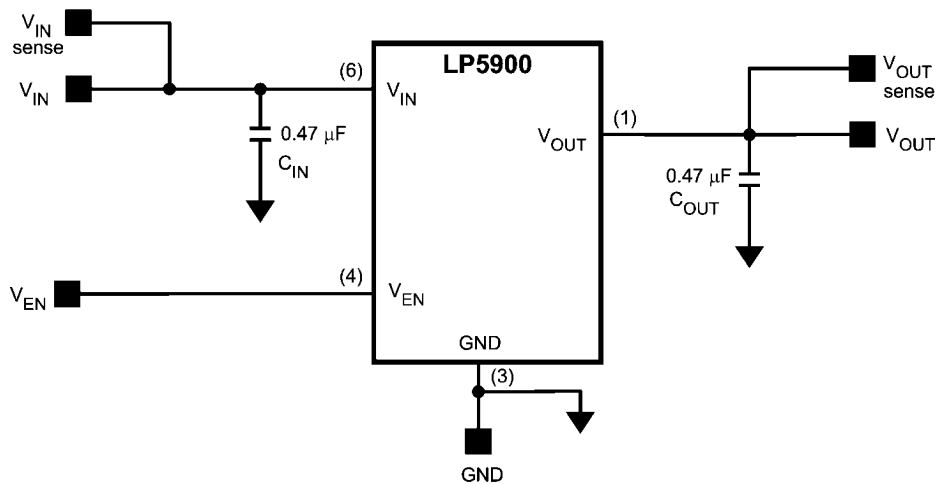

Evaluation Board Schematic.

20196804

PCB Layout

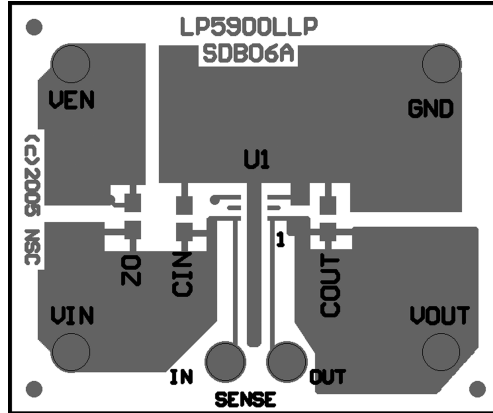

Evaluation Board Component and Pin Layout Board Size:- 1.200" x 1.000"
20196810

Hardware

Designator	Value	Amount	Footprint	Note
U1	LP5900SD	1	SDB06A	
CIN	0.47 μ F	1	0603	X7R, X5R
COUT	0.47 μ F	1	0603	X7R, X5R
IN, OUT, IN SENSE, OUT SENSE, ON/OFF, GND	Test Pins	6		

Notes

AN-1494

Notes

THE CONTENTS OF THIS DOCUMENT ARE PROVIDED IN CONNECTION WITH NATIONAL SEMICONDUCTOR CORPORATION ("NATIONAL") PRODUCTS. NATIONAL MAKES NO REPRESENTATIONS OR WARRANTIES WITH RESPECT TO THE ACCURACY OR COMPLETENESS OF THE CONTENTS OF THIS PUBLICATION AND RESERVES THE RIGHT TO MAKE CHANGES TO SPECIFICATIONS AND PRODUCT DESCRIPTIONS AT ANY TIME WITHOUT NOTICE. NO LICENSE, WHETHER EXPRESS, IMPLIED, ARISING BY ESTOPPEL OR OTHERWISE, TO ANY INTELLECTUAL PROPERTY RIGHTS IS GRANTED BY THIS DOCUMENT.

TESTING AND OTHER QUALITY CONTROLS ARE USED TO THE EXTENT NATIONAL DEEMS NECESSARY TO SUPPORT NATIONAL'S PRODUCT WARRANTY. EXCEPT WHERE MANDATED BY GOVERNMENT REQUIREMENTS, TESTING OF ALL PARAMETERS OF EACH PRODUCT IS NOT NECESSARILY PERFORMED. NATIONAL ASSUMES NO LIABILITY FOR APPLICATIONS ASSISTANCE OR BUYER PRODUCT DESIGN. BUYERS ARE RESPONSIBLE FOR THEIR PRODUCTS AND APPLICATIONS USING NATIONAL COMPONENTS. PRIOR TO USING OR DISTRIBUTING ANY PRODUCTS THAT INCLUDE NATIONAL COMPONENTS, BUYERS SHOULD PROVIDE ADEQUATE DESIGN, TESTING AND OPERATING SAFEGUARDS.

EXCEPT AS PROVIDED IN NATIONAL'S TERMS AND CONDITIONS OF SALE FOR SUCH PRODUCTS, NATIONAL ASSUMES NO LIABILITY WHATSOEVER, AND NATIONAL DISCLAIMS ANY EXPRESS OR IMPLIED WARRANTY RELATING TO THE SALE AND/OR USE OF NATIONAL PRODUCTS INCLUDING LIABILITY OR WARRANTIES RELATING TO FITNESS FOR A PARTICULAR PURPOSE, MERCHANTABILITY, OR INFRINGEMENT OF ANY PATENT, COPYRIGHT OR OTHER INTELLECTUAL PROPERTY RIGHT.

LIFE SUPPORT POLICY

NATIONAL'S PRODUCTS ARE NOT AUTHORIZED FOR USE AS CRITICAL COMPONENTS IN LIFE SUPPORT DEVICES OR SYSTEMS WITHOUT THE EXPRESS PRIOR WRITTEN APPROVAL OF THE CHIEF EXECUTIVE OFFICER AND GENERAL COUNSEL OF NATIONAL SEMICONDUCTOR CORPORATION. As used herein:

Life support devices or systems are devices which (a) are intended for surgical implant into the body, or (b) support or sustain life and whose failure to perform when properly used in accordance with instructions for use provided in the labeling can be reasonably expected to result in a significant injury to the user. A critical component is any component in a life support device or system whose failure to perform can be reasonably expected to cause the failure of the life support device or system or to affect its safety or effectiveness.

National Semiconductor and the National Semiconductor logo are registered trademarks of National Semiconductor Corporation. All other brand or product names may be trademarks or registered trademarks of their respective holders.

Copyright© 2007 National Semiconductor Corporation

For the most current product information visit us at www.national.com



National Semiconductor Americas Customer Support Center
 Email: new.feedback@nsc.com
 Tel: 1-800-272-9959

National Semiconductor Europe Customer Support Center
 Fax: +49 (0) 180-530-85-86
 Email: europe.support@nsc.com
 Deutsch Tel: +49 (0) 69 9508 6208
 English Tel: +49 (0) 870 24 0 2171
 Français Tel: +33 (0) 1 41 91 8790

National Semiconductor Asia Pacific Customer Support Center
 Email: ap.support@nsc.com

National Semiconductor Japan Customer Support Center
 Fax: 81-3-5639-7507
 Email: jpn.feedback@nsc.com
 Tel: 81-3-5639-7560